

Metering Pump Series GMA

Main technical characteristics

- Flowrate up to 50 LPH
- Pressure up to 12 bar
- Mechanically actuated PTFE diaphragm
- Stroke adjustment by variable eccentric minimising pulsation and shock
- Maximum temperature of pumped liquid: 40 °C
- Adjustment of flow rate while running or stopped: from 0 to 100%
- Accuracy: $\pm 2\%$ of rated flow from 10% to 100% stroke
- Suction lift: up to 4 m water
- Maximum suction pressure: 2 bar
- Housing in corrosion resistant glass fibre reinforced by thermoplastical material
- Life lubrication
- Options: double diaphragm, VARIPULSE® or frequency variation
- Integrable into an EH&S protection enclosure



Electrical characteristics of motors

General characteristics:

- Power supply:
 - 200/400V-50Hz, three-phase
 - 230/460V-60Hz, three-phase
 - 220V-50Hz, single-phase
- Enclosure of protection: IP55; Insulation: class F
- Options:
 - Single-phase motors: consult us

Flow & pressure curve

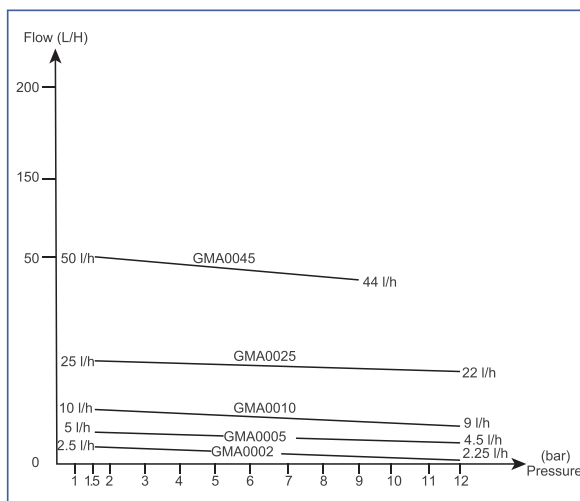

Note: 1. Max Capacity is @1.5bar;
2. All flow rate with motor at 50Hz, need multiply 1.2 for 60Hz.

Material of liquid ends

Liquid end	PVC	PVDF	316L	HV
Liquid end body	PVC	PVDF	316L	PVC
Valve body	PVDF	PVDF	316L	PVC
Valve seat	Aflas	PTFE	316L	PTFE
Valve ball	Ceramic	Ceramic	316L	316SS
Connection	PVDF	PVDF	316L	PVC
Diaphragm	PTFE	PTFE	PTFE	PTFE
Seals	Viton	PTFE	Viton	Viton

Other liquid end construction

- Sodium hypochlorite version
- Slurry version: 316L construction with alloy valve balls
- PVC/316L mixed version: PVC construction with 316L valve balls

Accessories

- The series GMA pumps are supplied with the accessories described in the following chart (except for 316L S.S. and slurries versions)
- Available on request: 3 or 4 Function valves, bleed 4 Function valves, pulsation dampeners, safety and back pressure valves, consult us

ACCESSORIES

For PVDF, PVC, Fluorinated Liquids and Mixed liquid ends:

- GMA 0002 to GMA 0045 versions: pumps supplied with 1 injection nozzle, 1 foot valve, 1 reinforced PVC hose (6 m) 6×12

For high viscosity liquid end:

- GMA 0002 to GMA 0045 versions: pumps supplied with: Suct. = 2 m PVC hose 15×23, Disch. = 3 m PVC hose, 1 injection nozzle.

World's Leading metering pump manufacturer

Product code

Code	Type	Capacity	Liquid end	Connection	Motor	Adjustment	Base	Options
	G M A							

Capacity

Code	LPH@P _{1.5bar} 50 / 60Hz	Stroker Speed (SPM) 50 / 60Hz	Pressure max (bar)	Motor Speed (SPM)		Motor Power	
				50Hz	60Hz	Standard 3-Ph	Optional 1- Ph
0002	2.5/3	36/43	12	1500	1800	90	180
0005	5/6	72/50		3000	3600	120	180
0010	10/12	144/173		3000	3600	120	180
0025	25/30	72/86		3000	3600	120	180
0045	50/60	144/172	10	3000	3600	120	180

Liquid end

Code	Description	Code	Description
P	PVC liquid end	V	High viscosity (PVC LE)
S	316L liquid end	K	Slurry (316SS LE)
T	PVDF liquid end	M	Mix (PVC LE)
F	PVC liquid end, used for sodium hypochlorite		
Z	Special material liquid end		

Motor

Code	Description
1	90W, 1500rpm, 3-50-220/380V, IP55/F/TEFC
2	120W, 3000rpm, 3-50-220/380V, IP55/F/TEFC
3	180W, 1500rpm, 1-50-220V, IP55/F/TEFC
4	180W, 3000rpm, 1-50-220V, IP55/F/TEFC
5	90W, 1500 or 1800rpm, 3-50-200/400V or 3-60-230/460V
6	120W, 3000 or 3600rpm, 3-50-200/400V or 3-60-230/460V
9	Other options, consult us

Base

Code	Description	Remark
N	N/A	Standard configuration
Y	Yes	

Dimensions & connections

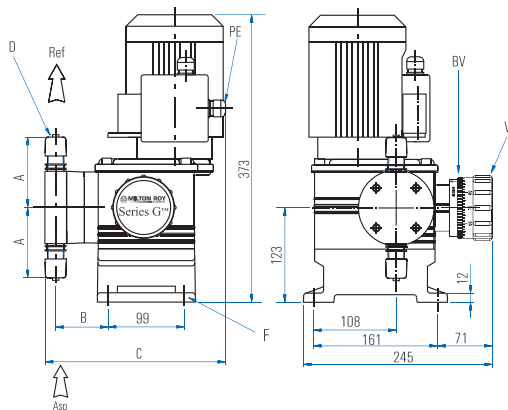

Asp: Suction **PE:** Motor gland **F:** 4 holes Φ 9mm
Ref: Discharge **V:** Stroke adjustment **D:** Connections
BV: Stroke adjustment locking
Note: standard configuration drawing without base plate.

Connection

Code	Description	PVC	PVDF	316L
P	NPT	1/4"M	1/4"M	1/2"F
Q	Pipe	DN15	-----	-----
R	Hose pipe	6x12	6x12	-----
L ⁽¹⁾	PE Soft Pipe	3/8"x1/2"	3/8"x1/2" ⁽²⁾	-----
H	High viscosity application: suc./disc.	15x23/9x12	-----	-----
X	Special option, consult us. marked the req's in purchase order.			

Note: Standard configuration is in shadow.
 (1)The maximum working pressure for PE pipe connection is 10bar.
 (2)Standard config is PE pipe, When PVDF pipe (length=6m)request, consult.

Adjustment

Code	Description	Remark
M	Manual adjustment	Standard configuration
F	Frequency inverter, 3-50-220/380V, 4-20mA input.	
P	Varipulse® controller (manual/analog/digital)	On site / remote

Options

Code	Description	Remark
N	N/A	Standard configuration
B	Double diaphragm with pressure gauge	
C	Double diaphragm with pressure switch (*)	
D	Double diaphragm with pressure gauge & switch(*)	

(*): Code C or D has included base plate in the structure, please use code "N" for the base plate in such a application.

Type	Dimensions (mm)	Liquid end Connections	PVDF/PVC/Mixed			HV
			R	P	H	
GMA0002	A		91	102	105	
GMA0005	B		68	68	83	
GMA0010	C		234	236	253	
GMA0025	A		91	102	108	
GMA0045	B		69	68	73	
	C		235	236	243	

Connections: R - Reinforce PVC hose.
 P - 1/2NPT female
 H - Suction: reinforce PVC hose 15x23; Discharge: PVC hose 9x12.

Weight & packing

Type	Net Weight ⁽¹⁾ (kg)	Gross Weight ⁽²⁾ (kg)	Packing ⁽²⁾ (L x W x H -mm)
GMA0002-GMA0045(PVC)	7	9	400x300x490
GMA0002-GMA0045(316L)	8	10	400x300x490

(1) Approximately (2) Standard cardboard package

Contact Us

Shanghai: 86 21 61211600

Singapore: 65 6242 0182

Seoul: 82 2 557 1110

Bangkok: 662 751 4777