

# Instruction Supplement

## ROYTRONIC EXCEL™ Series AD Electronic Metering Pump

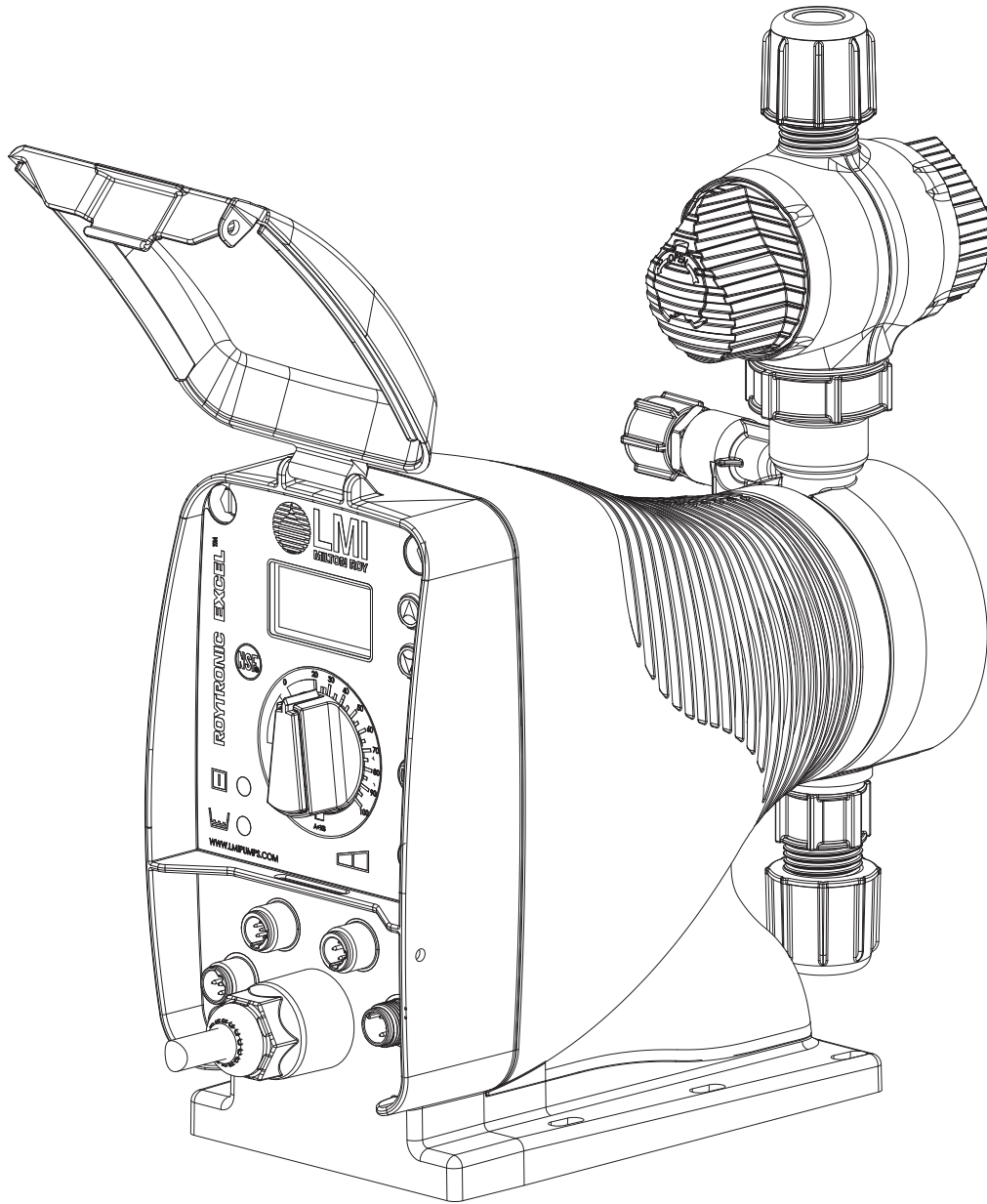

201 Ivyland Road  
Ivyland, PA 18974 USA  
TEL: (215) 293-0401  
FAX: (215) 293-0445  
<http://www.lmipumps.com>

ROYTRONIC EXCEL is a trademark of Milton Roy Company.

2046.A 6/2011



## Series AD Drive Assembly Parts List

Key No.	Description	Model	Part No.	Qty.
75	O-Ring	AD	48751	1
80	Spring	ADX1, ADX4	48997	1
		ADX5	48998	1
		ADX6	48999	1
90	EPU Shim	AD	48177	1
125	O-Ring	AD	48750	1
130	Retaining Ring	AD	48313	1
132	Stroke Bracket	AD	48600	1
134	Screw	AD	48824	2
136	Washer	AD	48823	2
140	Housing	AD	48599	1
150	Screw	AD	48249	2
155	Washer	AD	48310	2
160	Control Panel	AD2	48594	1
		AD8	48595	1
		AD9	48596	1
190	Nameplate	AD2	48842	1
		AD8	48843	1
		AD9	48844	1
195	Stroke Dial	ADX6	49308	1
230	O-Ring	AD	48861	1
240	Wire Harness	AD	49013	1
250	Screw	AD	41227	4
255	Screw	AD	38199	1
260	Stroke Shaft, Female	AD	48602	1
265	Stroke Shaft, Male	AD	48601	1

Key No.	Description	Model	Part No.	Qty.
270	O-Ring	AD	48309	1
285	Screw	AD	48311	5
310	Shaft Seal	AD	48158	1
320	Adapter Disk	ADX1	48167	1
		ADX4	48168	1
		ADX5	48169	1
		ADX6	48170	1
340	Clear Cover	AD	48603	1
503	Plunger Asm	ADX1	48534	1
		ADX4, ADX5, ADX6	48535	1
504	Pole Piece Asm	AD2X1, AD2X8	50659	1
		AD2X2, AD2X3, AD2X4 AD2X5, AD2X6, AD2X7, AD2X9	50660	1
		AD8, AD9	50661	1
505	Stroke Knob Asm	AD	50662	1
512	Power Cord Asm	ADXX1	48851	1
		ADXX2	48852	1
		ADXX3	48853	1
		ADXX5	48855	1
		ADXX6	48856	1
		ADXX7	48857	1
		ADXX8	48859	1
		513	Pulser	AD2
AD8	50664			1
AD9	50665			1

### EPU Resistance Chart

Model	EPU Resistance (Ohms) @ 20° C (68° F)*
AD2X1, AD2X8	77-89
AD2X2, AD2X3 AD2X5, AD2X6, AD2X7	294-338
AD8, AD9	16.3-18.7
*Let pump cool down for a minimum of 6 hours before checking the resistance, or else resistance measurements will be artificially high.	

# Series AD Drive Assembly Exploded View Diagram

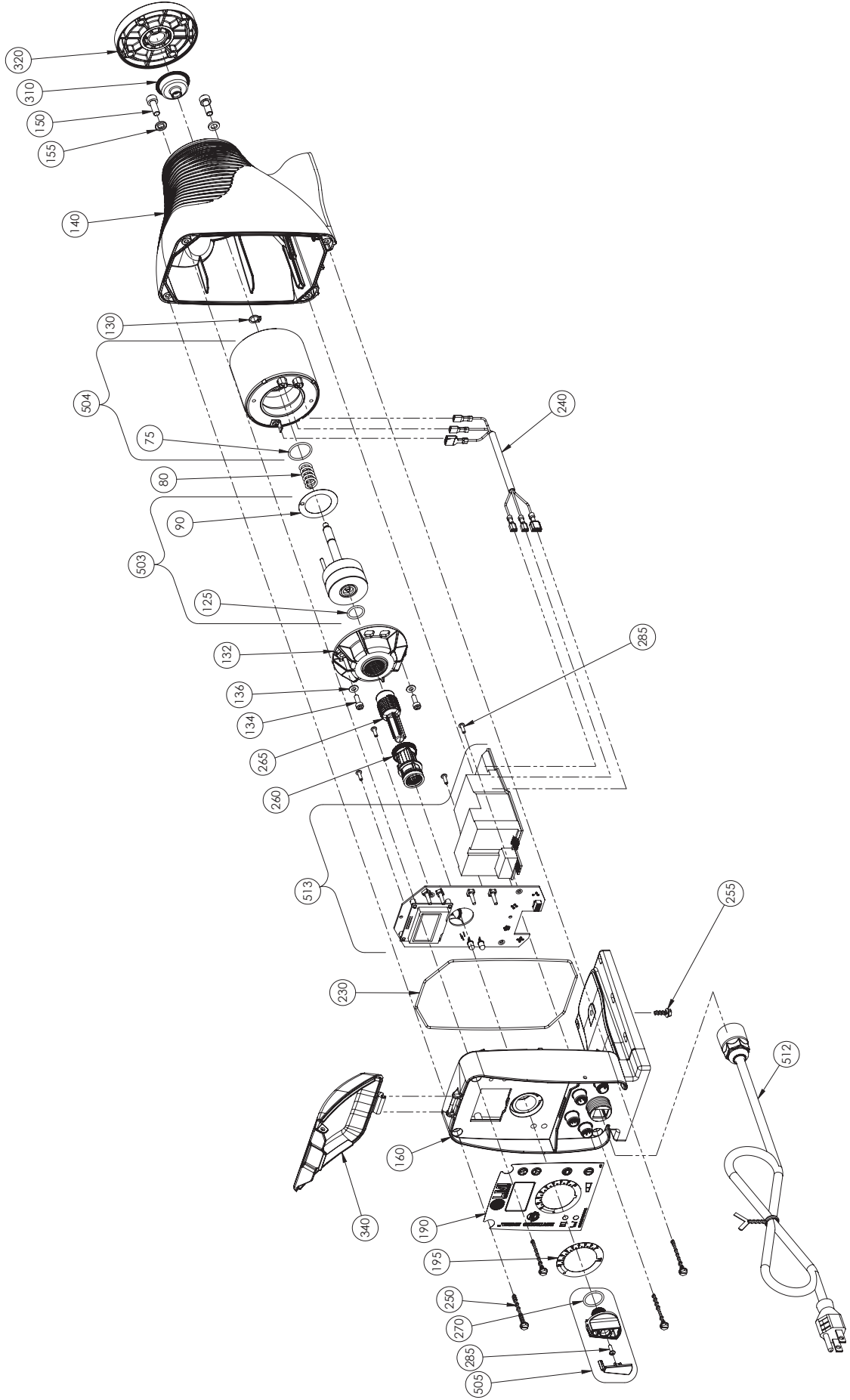

### Series AD2 Wiring Diagram

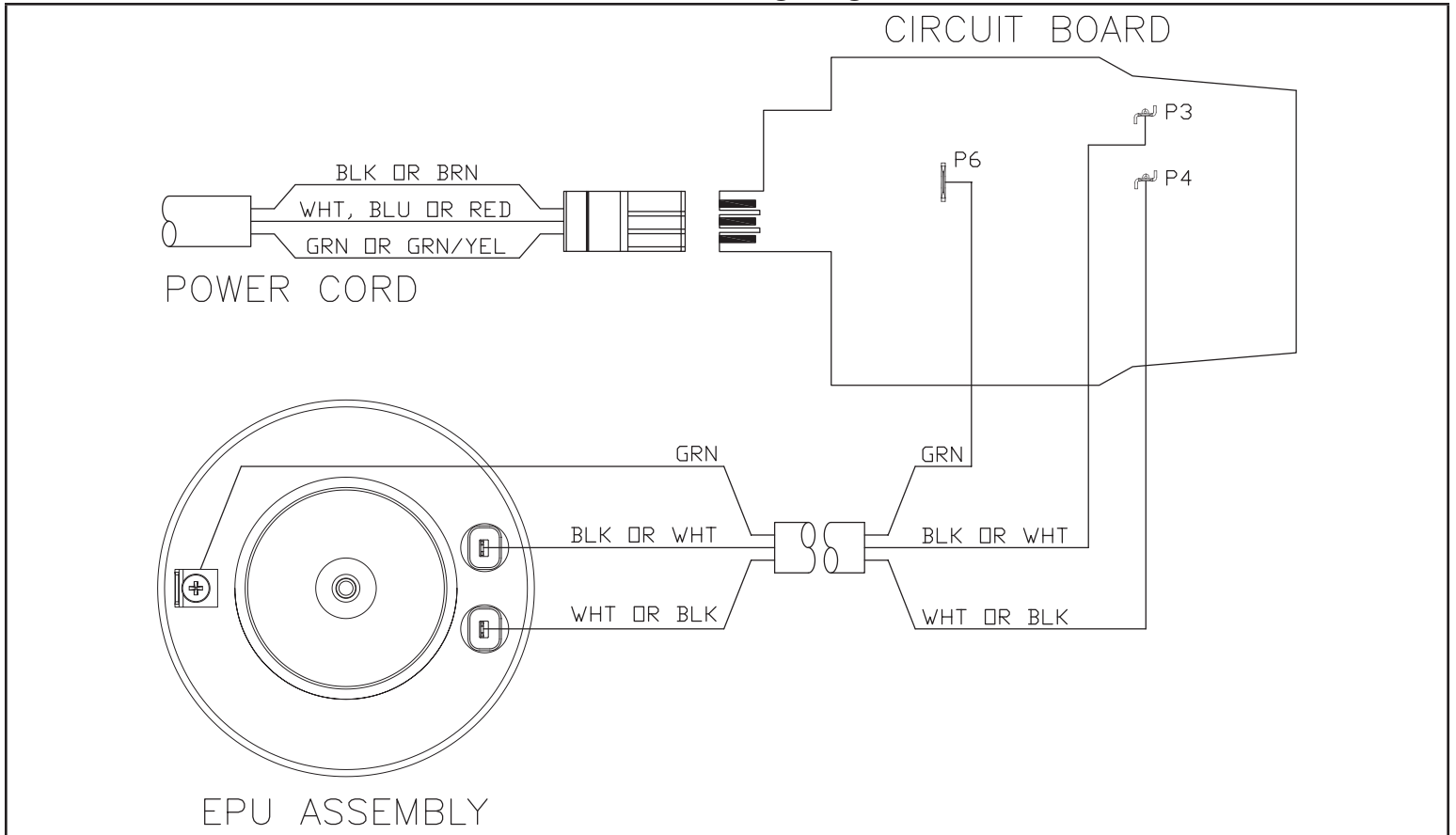

### Series AD8, AD9 Wiring Diagram

